

**COMPACT
SHORT STROKE CYLINDERS
KS-A SERIES Ø20- Ø100**

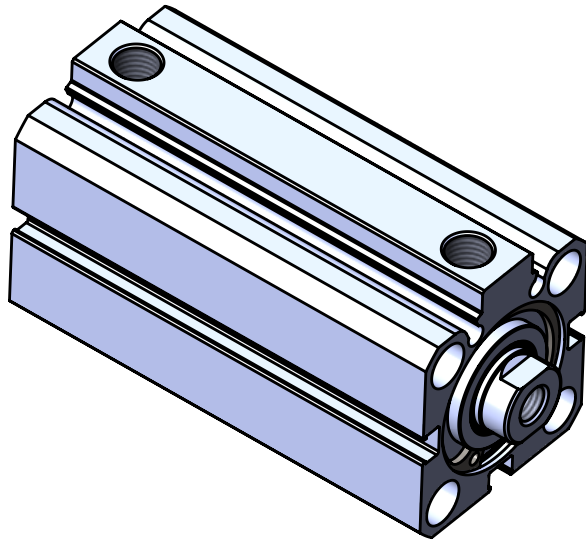

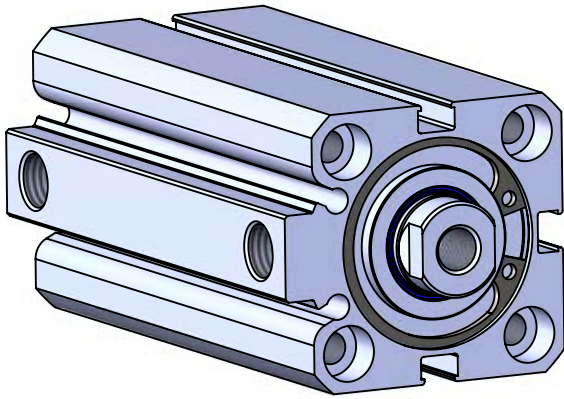

KS-A SERIES
SHORT STROKE CYLINDER
Ø20 - Ø100

SHORT STROKE
MAGNETIC CYLINDER

NEED HIGHER POWER IN A TIGHTER
SPACE? KS-A IS THE PERFECT CHOICE

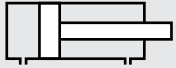

KS: SHORT STROKE CYLINDERS
WITH DOUBLE ACTING



KS-A: SHORT STROKE MAGNETIC
CYLINDERS WITH DOUBLE ACTING

Example of order:

KS-A 032-025 K1 M1
Product code Cylinder Ø Stroke Variants from Standard System

VARIANTS FROM STANDART SYSTEM:

- R1 : Stainless Steel Piston Rod (SS 304-SS 316)
- R4 : Stainless Steel Nut for Piston Rod (SS 304)
- R5: Piston Rod as CK45 (Hard Chrome Plated)
- M1: Extended male Piston Rod Thread
- M3: Special Piston Rod Thread
- M4: Extended Piston Rod
- K1: Seals for Max. 150°C (Viton)
- K4: Piston Rod Seal Viton

Force:

Cylinder Ø mm	Rod Ø mm	Thrust and traction forces (6 Bar)	
		Thrust force (N)	Traction force (N)
20	10	170	127
25	12	265	227
32	16	482	362
40	16	754	633
50	20	1178	990
63	20	1869	1682
80	25	3014	2721
100	30	4710	4286

Working Fluid:

Filtered and lubricated or filtered and not lubricated air.

Operating Temperature Range:

Polyurethane (PU) : (-20°C) - (+80°C)
Viton (FKM) : (-30°C) - (+150°C)

Maximum work pressure:

10 Bar

**KS-A SERIES
SHORT STROKE MAGNETIC SERIES**

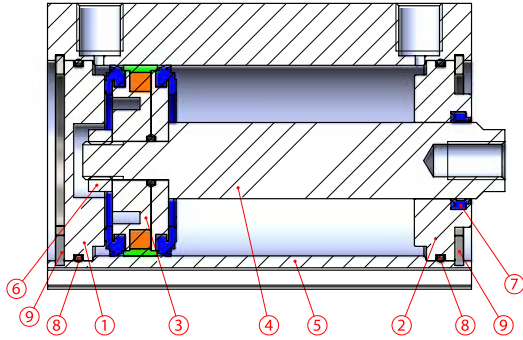

**KS SERIES
SHORT STROKE NO MAGNETIC SERIES**

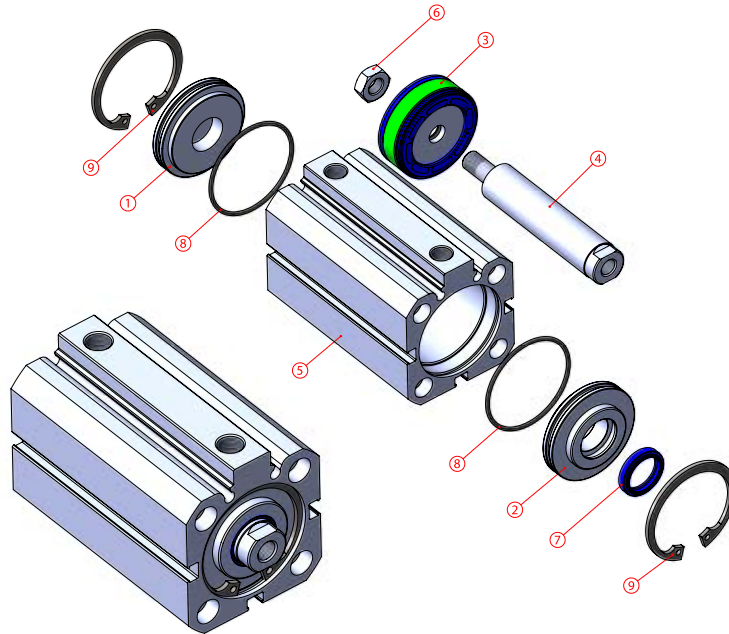
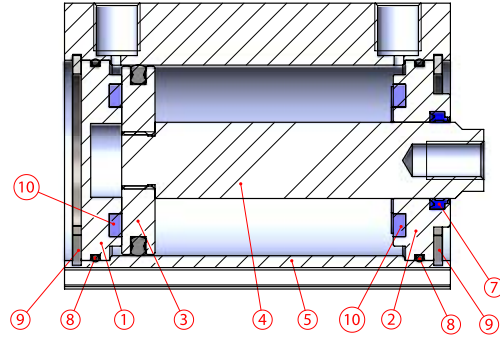

No	Material name	Characteristic		Pc.
		Magnetic	No Magnetic	
1	Rear Head	Bronze - 6082 Al. Eloxal Plated		1
2	Front Head	Bronze - 6082 Al. Eloxal Plated		1
3	Middle Piston	K58 PU + Al. + Polyacetal	6082 Al. + K62-K63 NBR	1
4	Piston Rod	X20Cr13 Hard Chrome Plated		1
5	Tube	Al Mg Si 0,5 + Eloxal Plated		1
6	Nut	Galvanized Steel		1
7	Rod Seal	PU		1
8	Head O-ring	NBR		2
9	Head Circlip	DIN 472 Steel		2
10	PU Bumper		PU 90	2

Not:

Ø20 - Ø63 Front and Rear Head:
Bronze
Ø80- Ø100 Front and Rear Head:
6082 Al. + Eloxal Plated
Ø20- Ø25 Magnetic Cylinder Middle Piston:
Brass
Ø32- Ø100 Magnetic Cylinder Middle Piston:
K58
Ø20- Ø100 No Magnetic Cylinder Middle
Piston:
6082 AL+ K62-K63 NBR

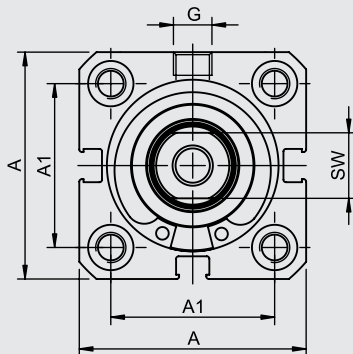
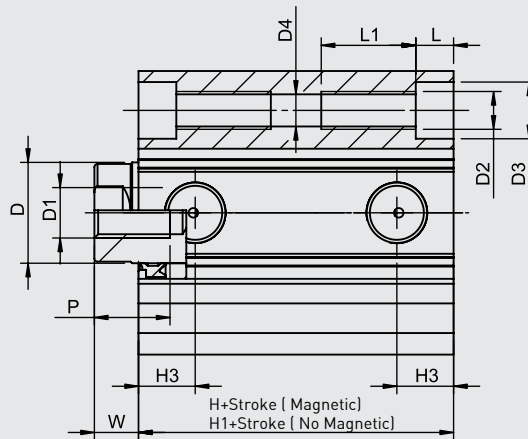

Ø 20 - Ø 25 CYLINDER

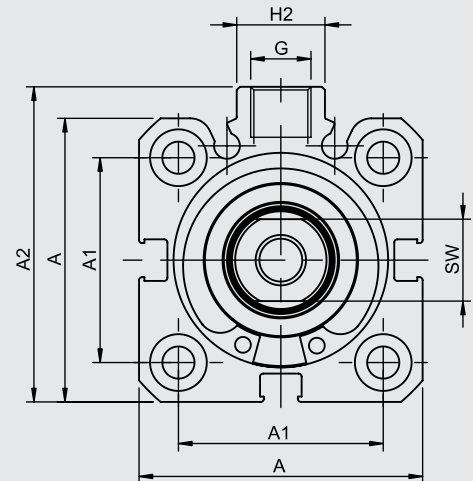

Ø 32 - Ø 100 CYLINDER

Cylinder Ø mm	A	A1	A2	D Ø	D1 Ø	D2 Ø	D3 Ø	D4 Ø	G	H	H1	H2	H3	L	L1	P	W	SW
20	36	22	-	10	M6	M5	7.5	4.15	M5	32	22	-	7.25	5	10	10	6	9
25	41	26	-	12	M6	M5	7.5	4.15	M5	33	23	-	7.25	5	10	10	6	10
32	45	32.5	50	16	M8	M6	9	5.1	1/8"	33	26	14	9	6	12	12	7	13
40	54	38	60	16	M8	M6	9	5.1	1/8"	39	31	15	11	6	12	12	7	13
50	64.5	46.5	70	20	M10	M8	11	6.7	1/8"	40.5	33	19	11.5	7	16	16	8	17
63	77.5	56.5	83	20	M10	M8	11	6.7	1/8"	46	35	19	12	7	16	16	8	17
80	96.5	72	102	25	M12	M10	13.5	8.6	1/8"	53.5	42	25	13.5	9	16	20	10	22
100	115	89	124	30	M12	M10	13.5	8.6	1/4"	62.5	50	25	15.5	9	16	20	10	27

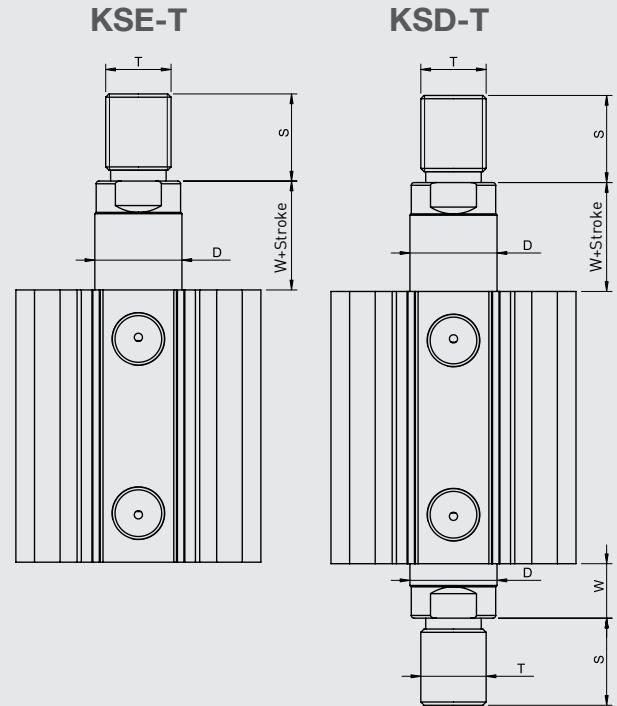
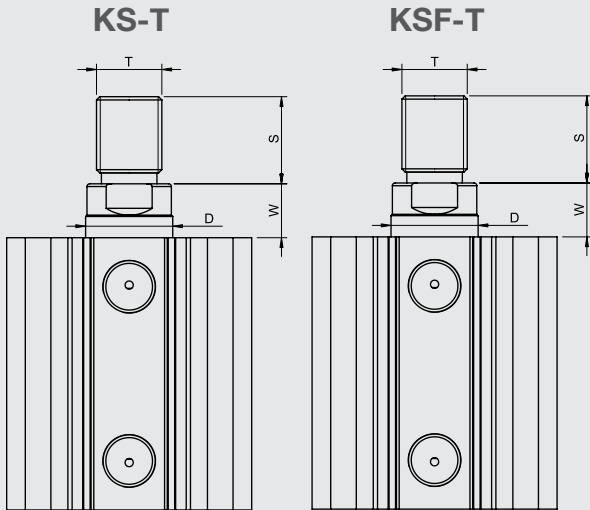
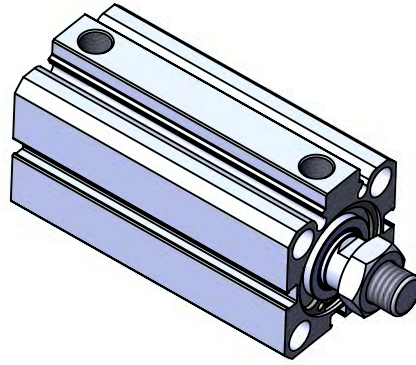

Cylinder type	Cylinder Ø mm	D	S	T	W
KS-KSF KSE-KSD	20	12	12	M8	6
	25	12	14	M10x1.25	6
	32	16	16	M12x1.25	7
	40	16	16	M12x1.25	7
	50	20	22	M16x1.5	8
	63	20	22	M16x1.5	8
	80	25	28	M20x1.5	10
	100	30	28	M20x1.5	10